



HARKEN[®]
PowerSeat
PWRs-G
PWRs-G. Compact
Instruction Manual



Please read these instructions carefully before operating equipment.



English Translation
Rev. 03 FT
PWRs-G_C 01-03-2019

Introduction	page	4
About this Manual	page	4
Glossary and Symbols	page	5
General Information	page	6
Identification Data and Plates on the Device	page	6
Model for Declaration of Compliance	page	7
Standard References	page	8
Technical Support Information	page	8
Safety Precautions	page	9
General Advice	page	9
Intended Use	page	9
Improper Use	page	10
Safety Devices	page	10
Personal Protective Equipment(PPE)	page	10
Residual Risks	page	10
PowerSeat PWRS-G	page	11
Device Description	page	11
<i>General</i>	page	11
<i>Dimensions</i>	page	12
<i>Safe Working Load</i>	page	13
<i>Rope Requirements</i>	page	13
<i>Vibration</i>	page	13
<i>Noise Emission</i>	page	13
Technical Data	page	14
<i>Motor</i>	page	14
Using the Device	page	15
<i>Checkig the Device Before Use</i>	page	15
<i>Adjusting the Accelerator Control Position</i>	page	16
<i>Adjusting the Control Lever Position</i>	page	17
<i>Primary Rope Installation Procedure</i>	page	17

<i>Preparing to Ascend</i>	page	20
<i>Ascent Procedure 1</i>	page	21
<i>Ascent Procedure 2</i>	page	22
<i>Using PowerSeat with a Fixed Anchorage</i>	page	23
<i>Descent Procedure 1</i>	page	25
<i>Descent Procedure 2</i>	page	26
<i>Fixed Anchorage Descent Procedure</i>	page	27
<i>Refueling</i>	page	27
<i>Transport and Storage</i>	page	27
PowerSeat PWRS-G.Compact	page	28
Description of Compact version	page	28
<i>General</i>	page	28
<i>Dimensions</i>	page	29
Using the Compact version Device	page	30
<i>Checking the Compact version Device Before Use</i>	page	30
<i>Primary Rope Installation Procedure on Compact version</i>	page	30
<i>Preparing to Ascent with the Compact version</i>	page	32
<i>Ascent Procedure with the Compact version</i>	page	32
<i>Using Compact version PowerSeat with a Fixed Anchorage</i>	page	33
<i>Descent Procedure with the Compact version</i>	page	35
<i>Fixed Anchorage Descent Procedure with the Compact version</i>	page	35
<i>Converting the PowerSeat PWRS-G in the Compact version</i>	page	36
Maintenance	page	37
Cleaning	page	37
Maintenance	page	37
Engine Maintenance	page	37
Dismantling and Disposal	page	37
Diagnosis and Fault Finding	page	38
Maintenance Schedule	page	38
Worldwide Limited Warranty	page	42

Introduction

ABOUT THIS MANUAL

This User Manual is an integral part of the device and aims to provide all the information needed for its safe and correct use and for proper maintenance.

If there are instructions you do not understand, contact Harken.

Keep the manual in a safe place for future consultation. This manual may be modified without notice. Updated versions are available on www.power-seat.com.

This manual is for qualified operators (refer to the Safety Information chapter for more information). Improper use of the device or incorrect maintenance could cause severe damage or death.

Harken accepts no responsibility for damage, personal injury or death caused by failure to observe the safety information and instructions in this Manual. The device must be used exclusively by qualified operators in possession of a certificate for temporary work at height with the use of access and positioning systems using ropes according to the current regulations of the Nation in which the device is used. This manual thus supplies information exclusively regarding the correct use of the device and does not substitute the training and certification needed for temporary work at height with the use of access and positioning systems using ropes.

GLOSSARY AND SYMBOLS

Intended Use – use of the device according to the information supplied in the instructions for use.

Improper Use – use of the device in a way different from that indicated in the instructions for use.

Qualified Operator – persons who have attended specialisation, training etc courses and are certified for temporary work at height with the use of access and positioning systems using ropes according to the current regulations of the Nation in which the device is used.

User - qualified operator of the device

Anchorage – point of attachment of the rope or device to a fixed point.

Primary (working) rope – main rope used for ascending or descending using the device (approved according to EN 1891).

Secondary (backup) rope – safety rope to protect the operator from falling if the primary rope breaks (approved according to EN 1891).

Fall arrest – individual protection device that brakes the fall of the user (EN353/2 approved).

Text preceded by the following symbols contains very important information or instructions, especially in regards to safety.

Failure to observe these may lead to:

danger for operators
invalidity of the contract warranty
refusal of the manufacturer to accept responsibility

**WARNING!**

this denotes the existence of the potential danger, which could cause injury or damage if the information or instructions are not followed

**NOTE!**

this denotes important information concerning the device

General Information

IDENTIFICATION DATA AND PLATES ON THE DEVICE

Each device is identified by a CE plate on which the reference data of the device are inscribed indelibly. Always quote these references when contacting the manufacturer or service centres.

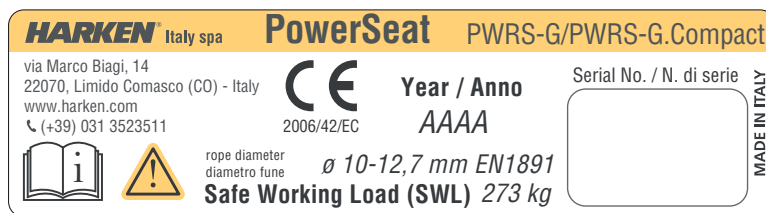

1	2		
3	4	5	6
7	8		

1. name of manufacturer
2. name of product and model
3. manufacturer's identification data
4. CE mark according to 2006/42/CE
5. year of manufacture
6. serial number in the format:

S XXXXX XXXXXXXXX

last two numbers of the year of manufacture of the device (e.g. 12 = the year 2012)

7. pictogram instructing you to read the manual before using the device
8. safety instruction on the diameter of the rope to use: minimum 10 mm, maximum 12.7 mm: this rope must be EN 1891 certified, plus indication of the Safe Working Load (SWL) of the device

The CE plate is on the chassis of the device:



MODEL FOR DECLARATION OF COMPLIANCE**DECLARATION OF EC COMPLIANCE****1. (All. IIA Dir. 2006/42/CE)**

The undersigned

Harken Italy S.p.A.

Via Marco Biagi, 14, 22070 Limido Comasco (CO) Italy

Telephone: +39 031/3523511, Fax: +39 031/3520031

Email: italy@harken.it, Web: www.harken.it

hereby declares that the machine:**LIFTING SYSTEM OF PEOPLE AND THINGS BY USING TECHNICAL ROPES**

Model

POWERSEAT PWRS-G**POWERSEAT PWRS-G.Compact**

Serial Nr.



Year of Manufacture

YYYY**complies with the essential requirements defined by the following directives:**

⇒ Directive 2006/42/CE of the European Parliament and Council of 17th May 2006 concerning "machines" amending directive 95/16/CE;

⇒ Regulations reference: UNI EN ISO 12100:2010

and authorises

Name and Surname:		
Adress: HARKEN ITALY S.p.A. Via Marco Biagi, 14	Post Code: 22070	Province: Como
City: Limido Comasco	Country: Italy	

to carry out the technical file for it

Certification services:	Bureau Veritas Italia SpA.	HARKEN ITALY S.p.A.
Certification Nr.:	XXXX-XXXX-XX-XXXX-XX-XXXX	
Date of Issue	MM/YYYY	
Limido Comasco, li	DD/MM/YYYY	<hr/> Legal representative

General Information

STANDARD REFERENCES

The device has been manufactured in conformity with the TECHNICAL REGULATIONS listed below:

Reference technical standards	
UNI EN ISO 12100:2010	Safety of machinery -- General principles for design -- Risk assessment and risk reduction
UNI EN ISO 13857:2008	Safety of machinery -- Safety distances to prevent hazard zones being reached by upper and lower limbs
UNI EN 349:2008	Safety of machinery - Minimum gaps to avoid crushing of parts of the human body
UNI EN 14118:2018	Safety of machinery - Prevention of unexpected start-up
EN ISO 13849-1:2016	Safety of machinery – Safety-related parts of control systems – Part 1: General principles for design
EN ISO 13849-2: 2013	Safety of machinery – Safety-related parts of control systems – Part 2: Validation
UNI EN ISO 13732-1:2009	Ergonomics of the thermal environment - Methods for the assessment of human responses to contact with surfaces - Part 1: Hot surfaces
UNI EN 614-1:2009	Safety of machinery - Ergonomic design principles - Part 1: Terminology and general principles
UNI EN 614-2:2009	Specification and qualification of welding procedures for metallic materials - Welding procedure test - Part 2: Arc welding of aluminium and its alloys
UNI EN 14120:2015	Safety of machinery - Guards - General requirements for the design and construction of fixed and movable guards
UNI EN 1005-1:2009	Safety of machinery - Human physical performance - Part 1: Terms and definitions
UNI EN 1005-3:2009	Safety of machinery - Human physical performance - Part 3: Recommended force limits for machinery operation
UNI EN 1005-4:2009	Safety of machinery - Human physical performance - Part 4: Evaluation of working postures and movements in relation to machinery
UNI EN ISO 3746:2011	Acoustics - Determination of sound power levels and sound energy levels of noise sources using sound pressure - Survey method using an enveloping measurement surface over a reflecting plane
UNI EN ISO 11204:2010	Acoustics -- Noise emitted by machinery and equipment -- Determination of emission sound pressure levels at a work station and at other specified positions applying accurate environmental corrections
UNI EN ISO 4871:2009	Acoustics - Declaration and verification of noise emission values of machinery and equipment
UNI EN ISO 11806-1:2012	Agricultural and forestry machinery - Portable hand-held combustion engine driven brush cutters and grass trimmers - Safety requirements and testing
UNI EN ISO 7000:2014	Graphical symbols for use on equipment -- Registered symbols

TECHNICAL SUPPORT INFORMATION

The PowerSeat is covered by a warranty, as laid down in the general conditions of sale. If during the warranty period the device proves defective or suffers breakages, as indicated in the warranty, the manufacturer, after checking the device, will repair or replace the defective components. You are reminded that modifications carried out by the user, without explicit written authorisation from the manufacturer, will invalidate the warranty and relieve the manufacturer of any responsibility for damage caused by the defective product. The same considerations apply when spare parts that are not original or different from those explicitly indicated by the manufacturer as “safety devices” are used. For all these reasons we advise customers to contact Harken Technical Support.

GENERAL ADVICE**WARNING!**

read the instructions in this manual attentively and carefully follow the indications it contains before using the PowerSeat

Use of the PowerSeat is restricted to qualified operators who are certified for temporary work at height with the use of access and positioning systems using ropes according to the current regulations of the Nation in which the device is used.

Harken is not responsible for damage caused by the PowerSeat to people, animals or property in the case of:

- use of the PowerSeat by operators without proper certification.
- improper use of the PowerSeat
- lack of proper maintenance, as indicated in the Maintenance chapter of this Manual
- unauthorised modifications or changes
- use of spare parts that are not original or specific for the model
- total or partial failure to observe the instructions
- usage contrary to specific national regulations

For safety information on the use of the engine, consult the Engine Manual supplied together with this Manual

INTENDED USE

The PowerSeat is designed to help qualified operators ascend a rope using the engine and descend using a passive manual device. The PowerSeat is not safety equipment and is not a Personal Protective Equipment. It must always be used in combination with a secondary rope to which is connected the fall arrest device fixed to the operator's harness by a cord with an energy absorber, and must satisfy the requirements of EN 363 on individual systems for the protection against falling from heights.

Use the PowerSeat only in sufficiently ventilated areas, as the engine exhaust gases contain carbon monoxide.

In order to use the PowerSeat a risk analysis, and rescue plan must have been drawn up, as required by current regulations of the nation where the device is used on temporary work at height and the use of access and positioning systems using ropes.

The following guidelines must also be considered:

- ISO 22846: Personal equipment for protection against falls (Part 1/Part 2)
- IRATA: International Code of Practice.
- C(HSW)R: The Construction (Health, Safety and Welfare) Regulations.
- LOLER: The Lifting Operations and Lifting Equipment Regulations.
- MHSWR: The Management of Health and Safety at Work Regulations.
- PUWER: The Provision and Use of Work Equipment Regulations

This list is not complete and it is the responsibility of the qualified operator to be aware of current regulations in his country on temporary work at height and the use of access and positioning systems using ropes or other regulations relating to his specific sector of work.

Safety Precautions

IMPROPER USE

The machine must not be used:

- for purposes different from those outlined in “Intended use” chapter, or for purposes not mentioned in this manual or different from those mentioned
- if unauthorised modifications or interventions have been carried out
- in an explosive atmosphere
- after it has fallen from a height of more than 1mtr onto a hard surface. In this case the device must be returned to the manufacturer or to a Harken authorised repair centre.

SAFETY DEVICES

The following safety devices are installed:

- Fall arrest attachment consists of strap and carabiner locked to the main support plate certified according to EN 1275; EN 362 Standards.
- Plastic cover on the central support for protecting the device from contact shocks and rope jamming
- Shaped plastic guard between the descending knob and the rope entry on the winch to prevent the rope jamming and tangling.

PERSONAL PROTECTIVE EQUIPMENT (PPE)

The device bears an adhesive label reminding you of the obligation:

- to use gloves
- to use ear plugs or ear muffs



RESIDUAL RISKS

You must pay attention to the following residual risks present when using PowerSeat:



WARNING! Rotating Parts Trapping Risk

Always wear clothing and protective gloves that are form fitting. Avoid loose gloves or clothing and always follow the instructions in the manual



WARNING! Noise Risk

Always wear suitable ear protection and always follow the instructions of the manual



WARNING! Vibration Risk

Always wear suitable protection and always follow the instructions of the manual



WARNING! Risk of Falling

Always use personal protective equipment and always follow the instructions of the manual

DEVICE DESCRIPTION - GENERAL

The PowerSeat is designed to help qualified operators ascend a rope and descend using a passive manual device.

The rope must be inserted in its housing in the vertical tube, through the deflector sheave, wrapped round the winch drum and locked in the rope grab.

When the engine is started, a transmission system rotates the drum and creates a traction force on the rope.

The engine is 4-stroke internal combustion and supplies the power for ascending, it has a pull start with automatic rewind and double action mechanical controls. Switch off is electrical.

During descent the engine is switched off and the operator uses the lever to open the rope grab and allow the rope to slide round the drum in a controlled descent..

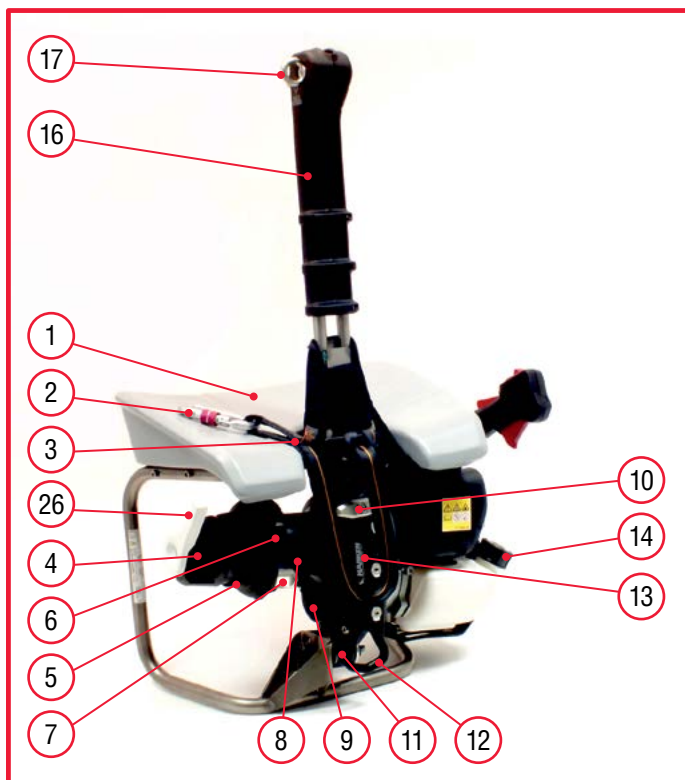

Pos.	Description
1	Seat
2	Snap-hook
3	Strop
4	Knob
5	Cover
6	Rope grab
7	Stripper arm
8	Winch Drum
9	Reduction gear casing
10	Clamp
11	Damper
12	Anchorage point
13	Front plate

Pos.	Description
14	Fuel tank cap
15	Protezion
16	Front tube
17	Eyebolt
18	Pin
19	Engine
20	Engine "0/I" switch
21	Accelerator engage lever
22	Accelerator level
23	Accelerator control
24	Engine oil cap
25	Frame
26	Control lever

DEVICE DESCRIPTION - DIMENSIONS

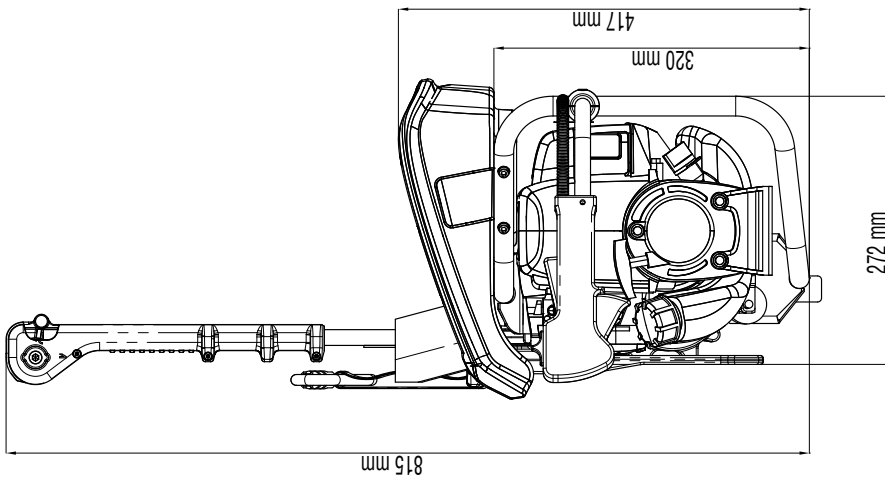
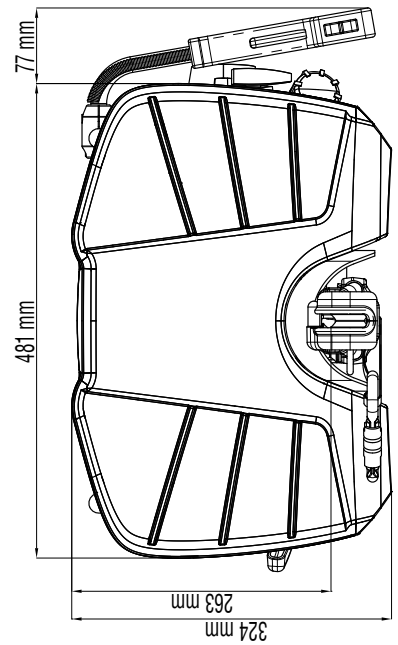
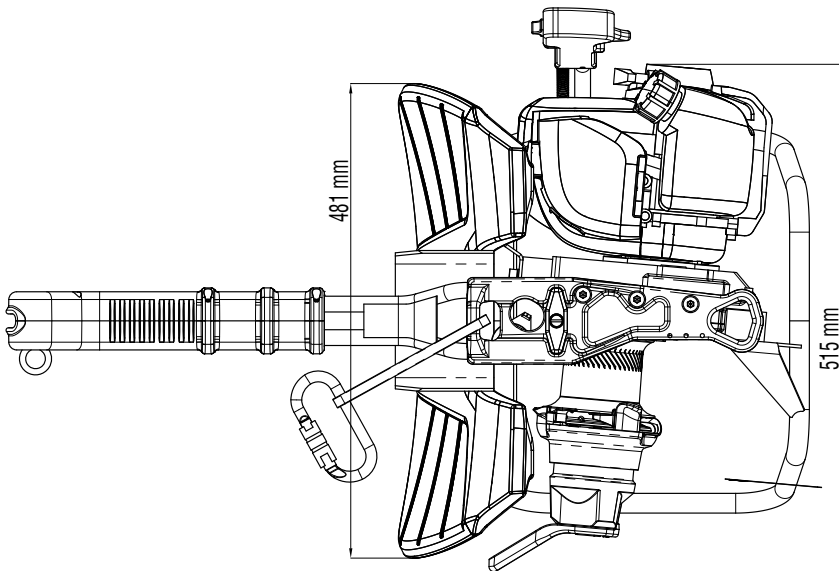
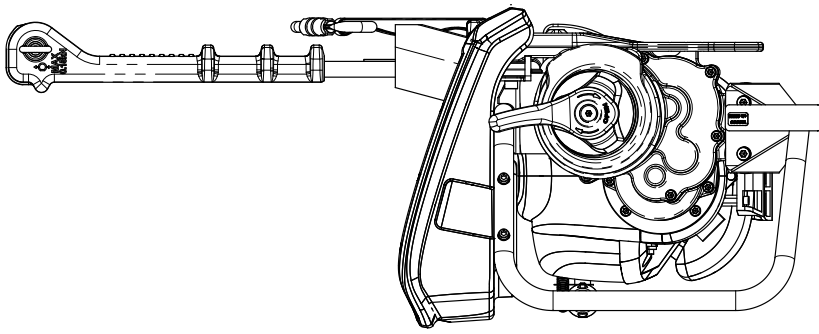

DEVICE DESCRIPTION - SAFE WORKING LOAD

The Safe Working Load of the PowerSeat is 273 Kg (600 lb).



WARNING!

Do not apply a load greater than the Safe Working Load to the PowerSeat

DEVICE DESCRIPTION - ROPE REQUIREMENTS



WARNING!

Use only EN1891 certified ropes with a diameter of between 10 - 12.7 mm (3/8" - 1/2")



WARNING!

Use only ropes in good condition



WARNING!

For correct maintenance of ropes consult the rope Usage Manual

VIBRATION

Values relate to 10 minute use time (the calculation has been performed using the highest value among three different test runs)

Worker's Job	Exposure action value (A(8) m/s ²)	
	Hand-arm (in/s ²)	Whole body (in/s ²)
PowerSeat User (exposure calculated estimating a 10 minute use, required time for an ascend of approx 40 m (131ft))	1,41 (55,5)	<0,1 (<3,9)

NOISE EMISSION

ACOUSTIC POWER LEVEL (L_{WA}) (ACCORDING TO ISO 3746):	96.2 dB(A)
AVERAGE SURFACE ACOUSTIC PRESSURE LEVEL ($L_{pA,d}$ (<i>medio</i>)) (ACCORDING TO ISO 3746):	$L_{pA,d}$ (average) = 81.3 dB
ACOUSTIC DATA MEASURED AT OPERATOR PLACE (ACCORDING ISO 11204) Uncertainty = 6 dB	SEATING OPERATIVE MODE L'_{pA} = 89.9 dB - C peak level at operator place: $L_{pC,peak}$ = 103.8 dB ASCENT PROCEDURE 2 L'_{pA} = 100.9 dB - C peak level at operator place: $L_{pC,peak}$ = 116.8 dB

PowerSeat PWRS-G

DEVICE DESCRIPTION - TECHNICAL DATA

Below are the principal technical data of the PowerSeat obtained with a rope 11mm (7/16") in diameter at a temperature of 20°C at sea level.

Rope	Semi static 10mm-12.7mm (1/8"-1/2") EN1891 rope
Safe Working Load	273 kg (600 lb)
Maximum Load on Seat	150 kg (330.7 lb)
Ascent speed	0-15 m/min (120 kg) (0-49 ft/min (264,5 lb)) 0-11 m/min (273 kg) (0-39 ft/min (600 lb))
Range	600m (273 kg load) (1968.5 lb (600 lb load))
Reduction Ratio	157,4:1
Weight when empty	14,5 kg (32 lb)
Dimensions	815.5 x 471 x 325 mm (32.1" x 18.5" x 12.8")
Recommended working temperature range	-5°C +40°C (23 to 104 °F) (*)
Recommended height range	0 m - 1500 m (0 ft - 4920 ft) (**)
(*) The PowerSeat may be used at temperatures outside the recommended range, but performance will be different from that indicated above. For more information contact Harken.	
(**) The PowerSeat may be used at heights outside the recommended range, but performance will be different from that indicated above. For more information contact Harken.	

DEVICE DESCRIPTION - ENGINE

Engine	Honda GX35
Type	4 stroke, overhead camshaft, single cylinder
Capacity	35,8 cm ³ (2.2 cu in)
Maximum Torque	1,6 Nm (1.2 lb) at 5500 rpm
Net Power	1 kW (1.3 hp) at 7000 rpm ¹
Weight when empty	3,46 kg (7.6 lb)
Dimensions	205 x 234 x 240 mm (8.1" x 9.2" x 9.4")
Engine oil capacity	0,10L (3.3 oz)
Fuel tank capacity	0,63L (21.4 oz)
Ignition system	transistorised magneto
Cooling system	forced air
Engine oil	SAE 10W-30, API SJ or later, for general use
Fuel	lead free petrol of at least 86 octane at pump (RON octane number at least 91)

USING THE DEVICE - CHECKING THE DEVICE BEFORE USE

Before and after every use, visually inspect the PowerSeat for traces of wear, damage or breakage. If such traces are present, do not use the device. If the worn or defective parts are not immediately replaced, the manufacturer will assume no responsibility for resulting damage or accidents.

In particular:



Check that the strop and carabiner are intact.



Check the movement of the rope grab cover.



Check that the rope grab knob is working by rotating the control lever and releasing it (CLOSE JAW).



Check that the rope grab knob is working by rotating the control lever and releasing it (OPEN JAW).



Inspect all screws and check that the marker on the screws and on the plate are aligned. In case of any misaligned contact a HARKEN service center.

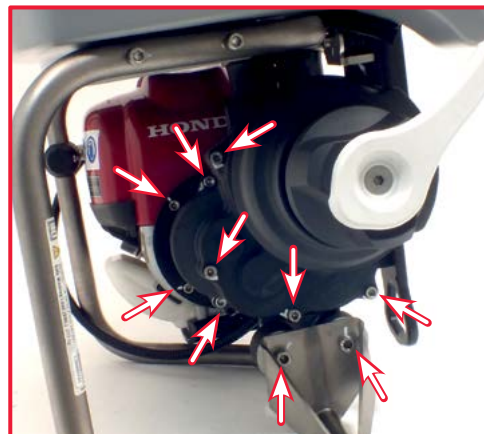

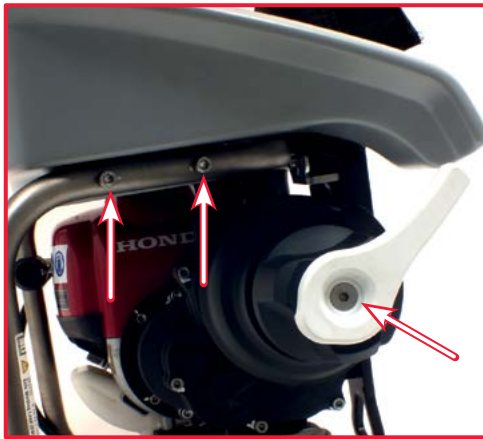

Inspect the lever control screw, and all screws that secure the seat to the frame and check that they are properly tightened.

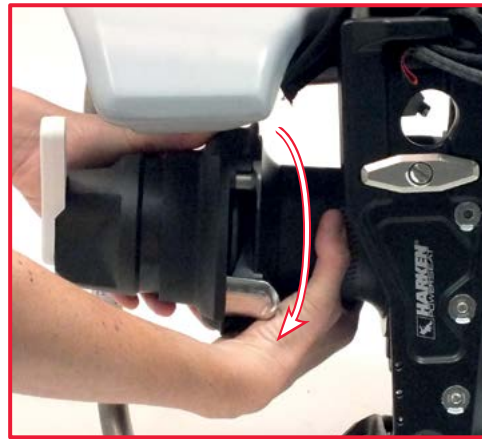

Rotate the winch drum clockwise by hand and make sure that it cannot rotate anticlockwise.



NOTE!

Before every use carry out a function check with the device unloaded to check for any problems with the engine.

USING THE DEVICE - ADJUSTING THE ACCELERATOR CONTROL POSITION

Before using the device verify the position of the accelerator control so that it is ergonomically comfortable for the operator, depending on the use that is expected.



1. Loose the screws of the accelerator control.



2. Place appropriately the accelerator control position.



3. Tighten the screws that anchor the accelerator control.



NOTE!

Verify that the accelerator control is away from the engine exhaust.

USING THE DEVICE - ADJUSTING THE CONTROL LEVER POSITION

Before starting to use the device it is possible to adjust the control lever position, so that it is ergonomically comfortable for the operator, considering the intended use.



1. Loose the control lever screw.



2. Place the control lever on one of 3 possible position.



2. Place the control lever on one of 3 possible position.



3. Tighten the control lever screw.

USING THE DEVICE - PRIMARY ROPE INSTALLATION PROCEDURE



1. Place the PowerSeat on the ground.

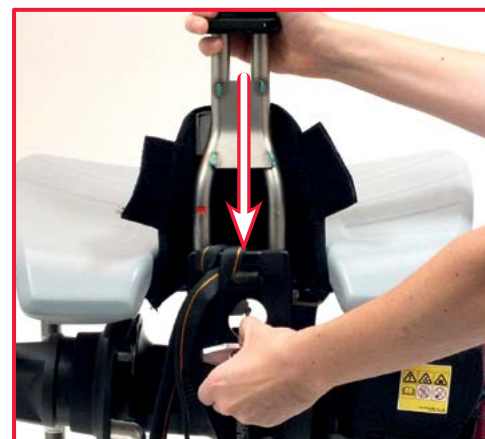

2. Pull open the clamp and slide the front tube into the housing.



WARNING!

Slide the front tube correctly into its housing until the red reference mark is no longer visible



3. Pass the rope inside the pin.



4. Fit the rope into the front tube.



5. Pass the rope round the pulley.



6. Make sure the rope has been fitted correctly into its housing.



7. Wind the rope clockwise around the winch drum.



WARNING!

Take at least two turns of the rope around the winch drum, and if it slips under load increase the number of turns to a maximum of four, taking care not to overlap the rope.



NOTE!

The number of turns needed round the winch drum depends on the load and the condition of the rope. Check the device's descending capacity in its working configuration. Before use ascend with the device, no more than 1 mtr (3,28 ft) and check, according to the descent procedure 1, that it's descending smoothly. In case of difficulties unwind the rope, and reduce the turns to not less than 2 wraps, until you have the optimal configuration.



8. Pass the rope over the stripper arm.



9. Fit the rope into the rope grab. Raise the cover to make this easier.



10. Position the rope inside the stopper.



11. Close the protective cover with the strap.

PowerSeat PWRS-G

USING THE DEVICE - PREPARING TO ASCEND

Install two ropes, Primary and Secondary, with separate anchorage points. Each rope must support at least 15 kN.

Install the Primary (or working) rope on the device as directed Primary Rope Installation Procedure above.

Attach the Secondary (or backup) rope is attached to the operator using a fall arrest device (EN353/2 approved) and energy absorber (EN355 approved).

Both ropes must be EN1891 Class A certified and have a diameter of between 10 (1/8") and 12.7 mm (1/2").

In the case of fault or breakage of the device or of the primary rope, the load will be immediately transferred to the secondary rope through the fall arrest device, thus constituting the anti-fall system.



WARNING!

Use the PowerSeat only with the primary and secondary ropes installed so as to create the anti-fall system described above.

To use the PowerSeat the operator must also wear:

1. A full EN 361 and EN813 certified harness to which the device is attached at the lower front attachment and the fall arrest device at the upper front attachment
2. An EN 795 B certified waist strop connected to the two side attachments of the harness and passing outside the front tube of the PowerSeat
3. Appropriate Individual Personal Protective Equipment (PPE) (e.g. helmet, gloves, protective glasses and ear plugs)
4. Suitable clothing, form fitting so it cannot catch on moving parts



Pos.	Descrizione
1	primary rope
2	secondary rope
3	fall arrest device
4	upper front attachment
5	full harness
6	waist strop
7	lower front attachment
8	side attachment points
9	helmet
10	protective glasses
11	ear plugs
12	gloves



WARNING!

Do not use the PowerSeat in the case of illness, tiredness or if under the influence of drugs or alcohol.

**WARNING!**

Keep your hands, feet and clothing etc away from the moving parts of the device.

**WARNING!**

During the ascent some parts of the engine could heat up. Handle the device with care to avoid injury.

**WARNING!**

During the use of the device any knots on the rope, if they are involved in the device circuit, may damage the device and cause dangerous conditions.

For further information on the use of the engine consult the Engine Manual supplied together with this manual.

USING THE DEVICE - ASCENT PROCEDURE 1

1. Install the primary rope on the device as indicated in the “Primary Rope Installation Procedure” paragraph
2. Sit on the device
3. Connect the fall arrest device to the harness as described in the “Preparing to Ascend” paragraph
4. Connect the waist strop to the two side attachment points of the harness, passing it outside the front tube of the PowerSeat.
5. Connect the snap-hook provided with the device to the lower front attachment point of the harness.

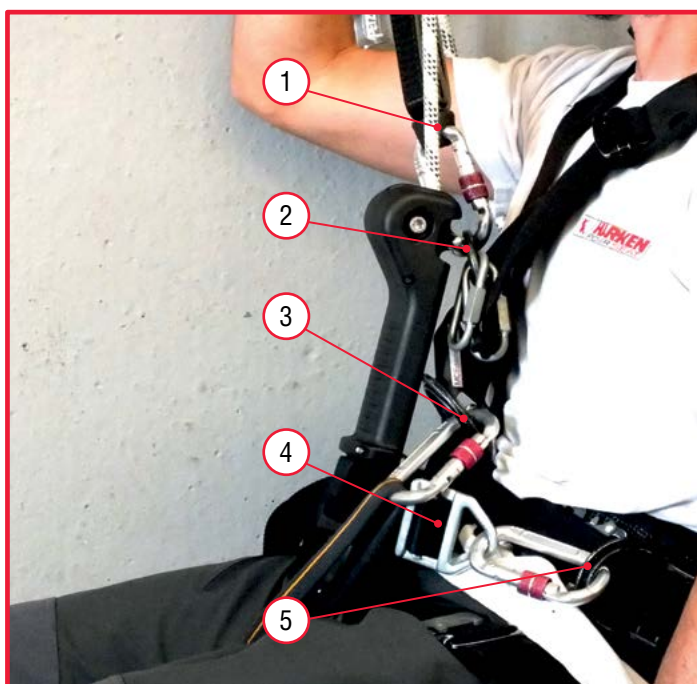

Pos.	Descrizione
1	Fall Arrest Device
2	Upper Front Attachment
3	Lower Front Attachment
4	Waist Strop
5	Side Attachment Point



6. Place the accelerator control in the " I " position.



7. Pull the starter cord.



8. Adjust the position of the accelerator control so it is ergonomically comfortable for the operator and away from the engine exhaust. To do this, loosen the fixing screw, position the accelerator control and retighten the fixing screw.

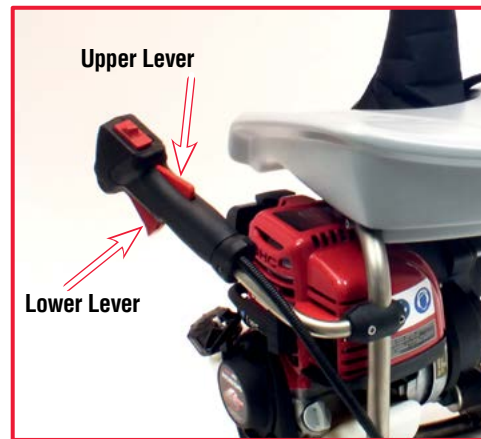

9. To ascend, fully press the upper red lever and at the same time adjust the speed by pressing the lower red lever.



ATTENZIONE!

Before using the device check that the rope is correctly installed.

USING THE DEVICE - ASCENT PROCEDURE 2

1. Install the primary rope on the device as indicated in the "Primary Rope Installation Procedure" paragraph
2. Adjust the accelerator control so that it is ergonomically comfortable for the operator, following the "Adjusting the Accelerator Control Position" procedure.
3. Place the accelerator control in the " I " position and pull the starter cord.
4. Start the device and position it at the height of the operator's shoulders
5. Connect the fall arrest device to the harness as described in the "Preparing to Ascent" paragraph
6. Connect the snap-hook supplied with the device to the lower front attachment point of the harness

In ascent procedure 2 the Waist strop is not used



7. To ascend, fully press the upper red lever and at the same time adjust the speed by pressing the lower red lever.



WARNING!

Before using the device check that the rope is correctly installed.

USING THE DEVICE - USING POWERSEAT WITH A FIXED POINT



NOTE!

To use the PowerSeat with a fixed point at least two operators are necessary. One operates the device and the second is connected by the primary rope to the device and to the secondary rope by the (EN353/2 approved) fall arrest device. Both ropes must be EN1891 certified and have a diameter of between 10 (1/8") and 12.7 mm (1/2"). The secondary rope must have an anchorage point that supports at least 15kN. The device is connected to a fixed anchorage point on the ground which must support at least 15kN



1. Pull the clamp and slide out the front tube.



2. Unscrew the four screws that fix the seat to the chassis with a n°5 hex Key.

PowerSeat PWRS-G



3. Remove the seat.

4. Adjust the accelerator control so that it is ergonomically comfortable for the operator, following the "Adjusting the Accelerator Control Position" procedure.
5. Place the control lever position following the "Adjusting the Control Lever Position" paragraph.
6. Install the primary rope on the device as indicated in the "Primary rope installation procedure" paragraph. In this case the primary rope will be used to lift the second operator.
7. Connect the anchorage point on the front plate of the device with the fixed anchorage point on the ground.
8. Place the accelerator control in the "I" position and pull the starter cord.
9. To operate the PowerSeat fully press the upper red lever and at the same time adjust the speed by pressing the lower red lever.



NOTE!

Before using the PowerSeat places on the ground be sure that the cable or the stand of the accelerator control are not under the device chassis.





WARNING!

To use the PowerSeat in the fixed point configuration the primary rope under load must leave the winch with a lateral and frontal angle of between $\pm 6^\circ$.

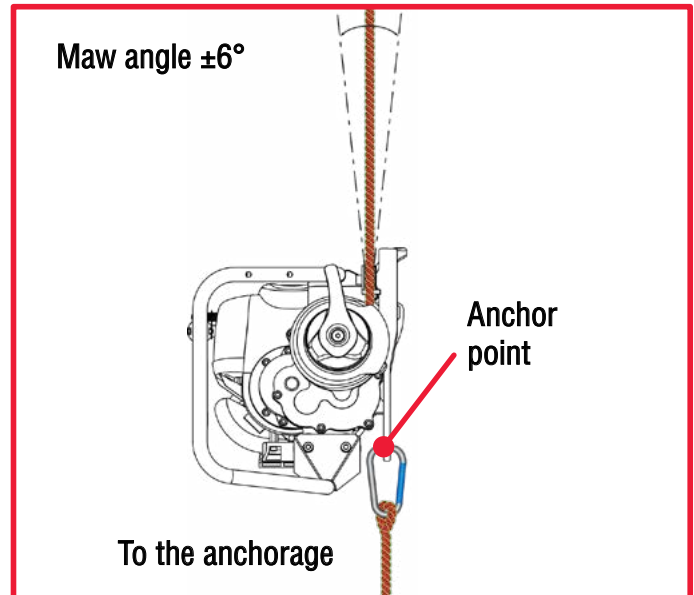
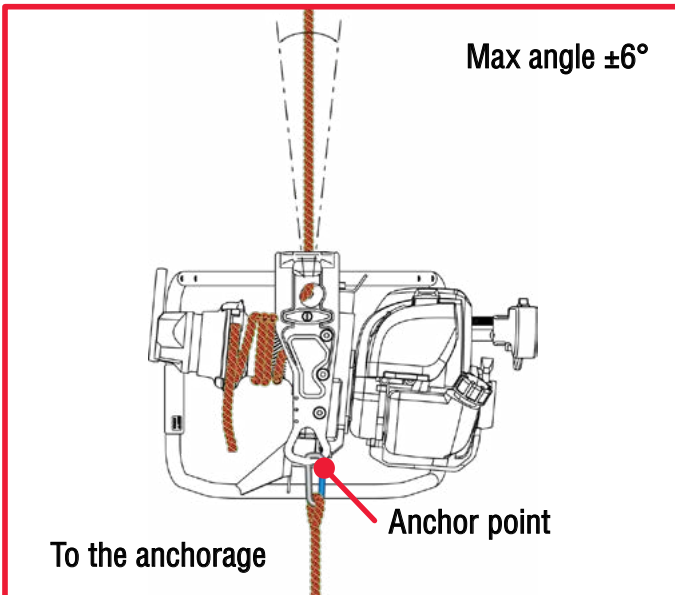

WARNING!

Before using the device check that the rope is correctly installed.

USING THE DEVICE - DESCENT PROCEDURE 1



1. Switch off the engine by moving the accelerator control to the "0" position.



2. With one hand grasp the rope leaving the winch.



NOTE!

If the accelerator control does not work, stop the engine by shutting off the carburettor air intake, moving the air lever to the CLOSED position (see Engine Manual).

PowerSeat PWRS-G



3. With the other hand, turn the control lever clockwise to allow the rope to slip on the winch drum and permit a controlled descent. To adjust descent speed, manually control the speed at which the rope leaves the winch by holding rope with arm out and bringing it in towards the winch drum. To stop the descent, release the control lever.



To facilitate descent, a carabiner can be fixed to the ring on the front tube and the primary rope passed through it.



NOTE!

Take care not to overbalance when getting off the seat.

Lower the PowerSeat until the operator's feet are firmly on the ground, but the unit is still suspended. Stand up and move on the seat. Now the device can be lowered to the ground and released from the rope.

USING THE DEVICE - DESCENT PROCEDURE 2



1. Switch off the engine by moving the accelerator control to the "0" position.



2. With one hand grasp the rope leaving the winch.



NOTE!

If the accelerator control does not work, stop the engine by shutting off the carburettor air intake, moving the air lever to the CLOSED position (see Engine Manual).



3. With the other hand, turn the control lever clockwise to allow the rope to slip on the winch drum and permit a controlled descent. To adjust descent speed, manually control the speed at which the rope leaves the winch. To stop the descent, release the control lever.

USING THE DEVICE - FIXED ANCHORAGE DESCENT PROCEDURE

1. Switch off the engine by moving the accelerator control to the " 0 " position



NOTE!

If the accelerator control does not work, stop the engine by shutting off the carburettor air intake, moving the air lever to the CLOSED position (see Engine Manual).

2. With one hand grasp the rope leaving the winch.

3. With the other hand, turn the control lever clockwise to allow the rope to slip on the winch drum and permit a controlled descent. To adjust descent speed, manually control the speed at which the rope leaves the winch. To stop the descent, release the control lever.

USING THE DEVICE - REFUELING

For refueling, consult the Engine Manual supplied together with this manual.

USING THE DEVICE - TRANSPORT AND STORAGE

Transport the device in the box supplied when it was purchased. For transport, empty the engine fuel tank. When not in use the device must be placed in its box to prevent it from knocks and shock, with the fuel tank empty. Protect the device from humidity and abrupt temperature change. Do not allow the device to come into contact with corrosive substances. Clean the device before storing.

PowerSeat PWRS-G.Compact

DESCRIPTION OF COMPACT VERSION - GENERAL

The PowerSeat Compact version maintains every device key features described in the "Device Description" paragraph.

This device version is designed to optimize the qualified operator's work when he works without seat or using the device with a fixed anchorage.

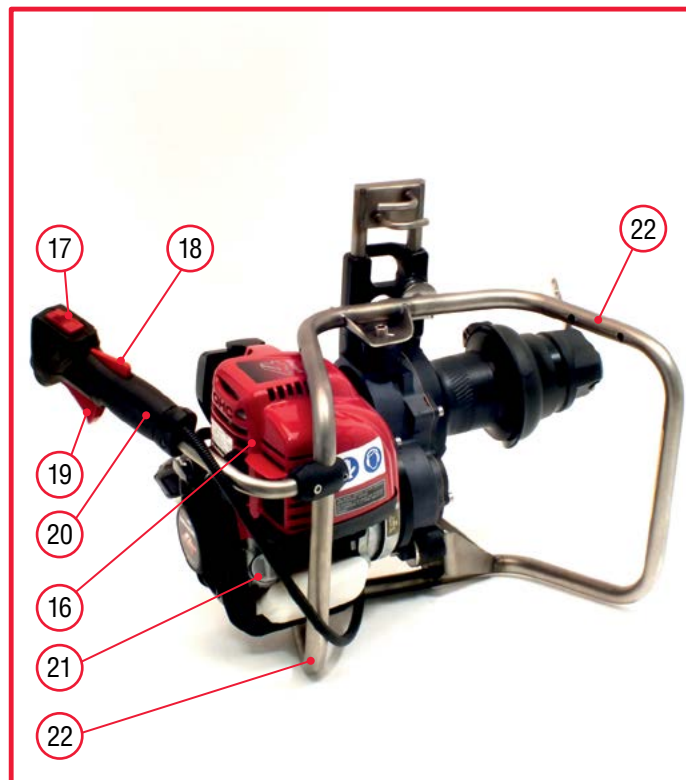
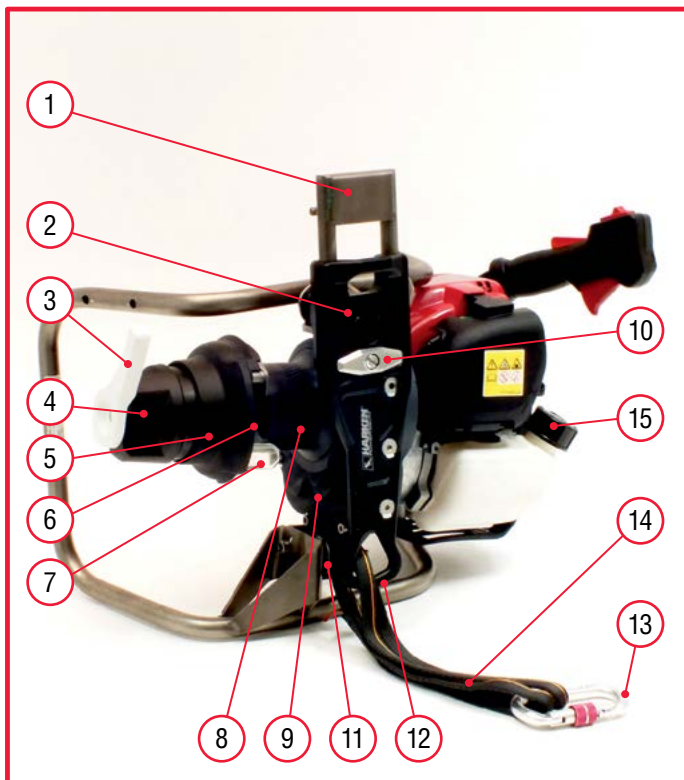

Pos.	Descrizione
1	Short tube
2	Front plate
3	Control lever
4	Knob
5	Cover
6	Rope grab
7	Stripper arm
8	Drum
9	Reduction gear casing
10	Clamp
11	Damper

Pos.	Descrizione
12	Anchorage point
13	Snap-hook
14	Strop
15	Fuel tank cap
16	Engine
17	Engine "0/1" switch
18	Accelerator engage lever
19	Accelerator lever
20	Accelerator control
21	Engine oil cap
22	Frame

DESCRIPTION OF COMPACT VERSION - DIMENSIONS

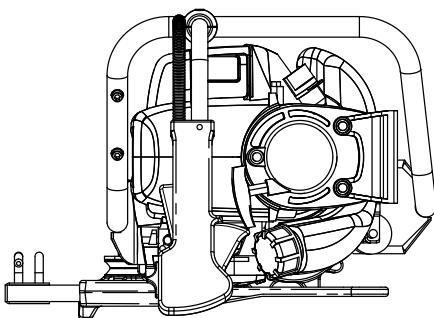
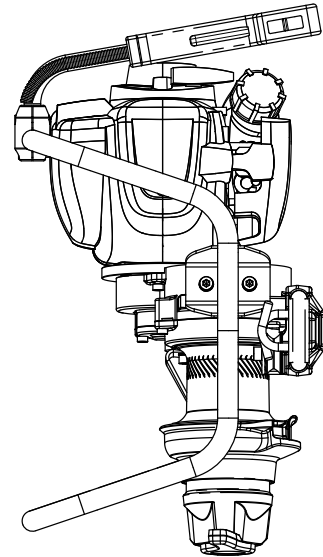
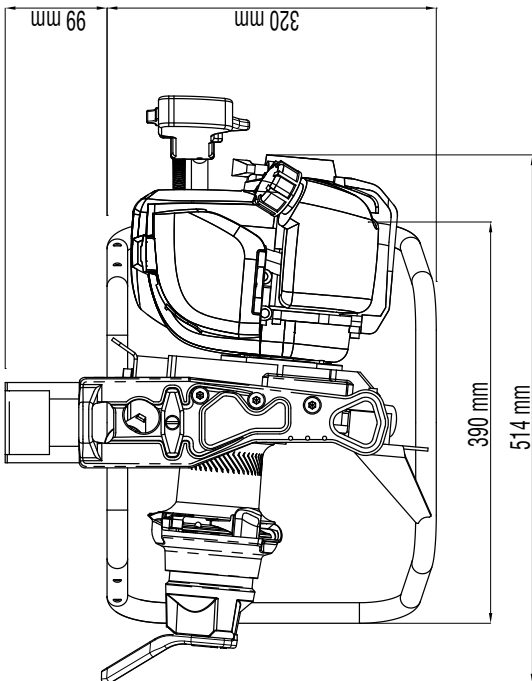
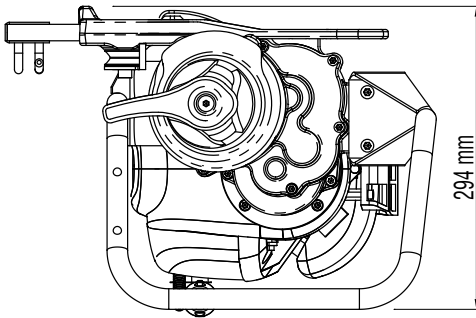

PowerSeat PWRS-G.Compact

USING THE COMPACT VERSION DEVICE - CHECKING THE COMPACT VERSION DEVICE BEFORE USE

Before and after using the PowerSeat Compact version follow the procedure described in the "Checking the Device Before Use" paragraph.

USING THE COMPACT VERSION DEVICE - PRIMARY ROPE INSTALLATION PROCEDURE ON COMPACT VERSION



1. Place the PowerSeat on the ground.



2. Pull open the clamp and slide the short tube into the housing.



WARNING!

Slide the front tube correctly into its housing until the red reference mark is no longer visible.



3. Remove the stop from upper anchorage point.



4. Fasten the stop on the lower anchorage point.



5. Pass the primary rope inside the pins.



6. Pass the rope round the pulley.

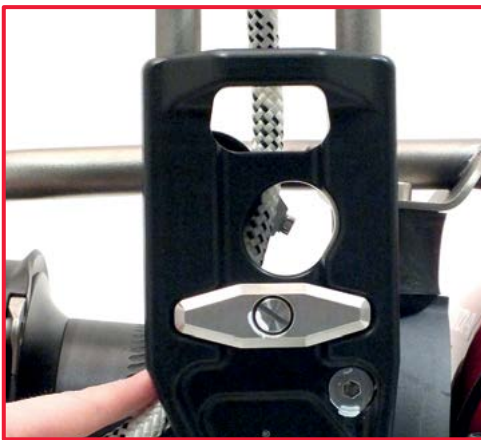

7. Make sure the rope has been fitted correctly into its housing.



8. Wind the rope clockwise around the winch drum.



WARNING!

Take at least two turns of the rope around the winch drum, and if it slips under load increase the number of turns to a maximum of four, taking care not to overlap the rope.



NOTE!

The number of turns needed round the winch drum depends on the load and the condition of the rope. Check the device's descending capacity in its working configuration. Before use ascend with the device, no more than 1 mtr (3,28 ft) and check, according to the descent procedure 1, that it's descending smoothly. In case of difficulties unwind the rope, and reduce the turns to not less than 2 wraps, until you have the optimal configuration.

PowerSeat PWRS-G.Compact



9. Pass the rope over the stripper arm.



10. Fit the rope into the rope grab. Raise the cover to make this easier.

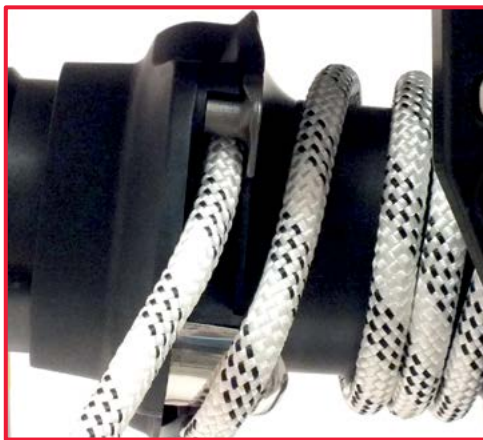

11. Position the rope inside the stopper.

USING THE COMPACT VERSION DEVICE - PREPARING TO ASCENT WITH THE COMPACT VERSION

To use the PowerSeat Compact version follow the procedure described in "Preparing to Ascent" paragraph.



WARNING!

Read carefully "Preparing to Ascent" paragraph before using the device.

USING THE COMPACT VERSION DEVICE - ASCENT PROCEDURE WITH THE COMPACT VERSION

1. Install the primary rope following "Primary Rope Installation Procedure on Compact version" paragraph.
2. Adjust the accelerator control so it is ergonomically comfortable for the operator, following the "Adjusting the Accelerator Control Position" procedure.
3. Place the accelerator control in the " I " position and pull the starter cord.
4. Start the device and position it at the height of the operator's shoulders.
5. Connect the fall arrest device to the harness as described in the "Preparing to Ascent" paragraph.
6. Connect the snap-hook supplied with the device to the lower front attachment point of the harness.

In the Ascent Procedure with the Compact Version the Waist strop is not used.



7. To ascend, fully press the upper red lever and at the same time adjust the speed by pressing the lower red lever.



ATTENZIONE!

Before using the device check that the rope is correctly installed.

USING THE COMPACT VERSION DEVICE - USING COMPACT VERSION POWERSEAT WITH A FIXED ANCHORAGE



NOTE!

To use the PowerSeat with a fixed point at least two operators are necessary. One operates the device and the second is connected by the primary rope to the device and to the secondary rope by the (EN353/2 approved) fall arrest device. Both ropes must be EN1891 certified and have a diameter of between 10 (1/8") and 12.7 mm (1/2"). The secondary rope must have an anchorage point that supports at least 15kN. The device is connected to a fixed anchorage point on the ground which must support at least 15kN.

1. Adjust the accelerator control so it is ergonomically comfortable for the operator, following the "Adjusting the Accelerator Control Position" procedure.
2. Set the control lever position following the "Adjusting the Control Lever Position" paragraph.
3. Install the primary rope on the device as indicated in the "Primary rope installation procedure on Compact version" paragraph. In this case the primary rope will be used to lift the second operator.
4. Connect the anchorage point on the front plate of the device with the fixed anchorage point on the ground.
5. Place the accelerator control in the " I " position and pull the starter cord.
6. To operate the PowerSeat fully press the upper red lever and at the same time adjust the speed by pressing the lower red lever.

PowerSeat PWRS-G.Compact



NOTE!

Before using the PowerSeat places on the ground be sure that the cable or the stand of the accelerator control are not under the device chassis.



WARNING!

To use the PowerSeat in the fixed point configuration the primary rope under load must leave the winch with a lateral and frontal angle of between $\pm 6^\circ$.

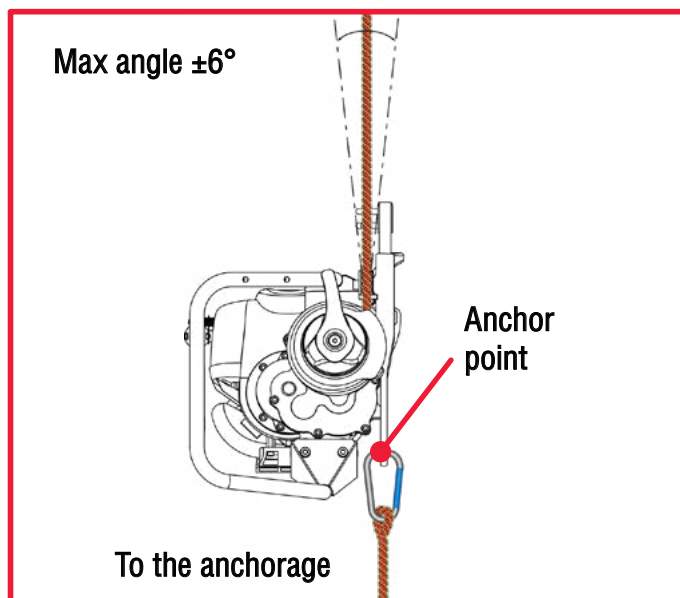
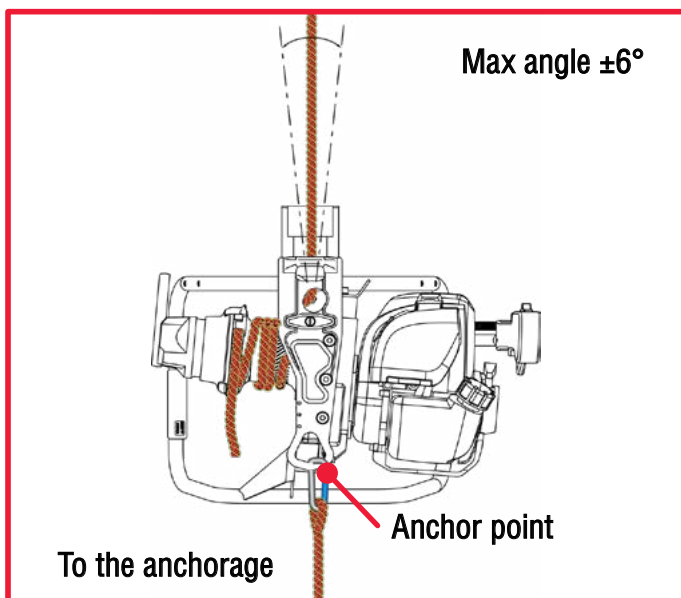

WARNING!

Before using the device check that the rope is correctly installed.

USING THE COMPACT VERSION DEVICE - DESCENT PROCEDURE WITH THE COMPACT VERSION



1. Switch off the engine by moving the accelerator control to the " 0 " position.



2. With one hand grasp the rope leaving the winch.



NOTE!

If the accelerator control does not work, stop the engine by shutting off the carburettor air intake, moving the air lever to the CLOSED position (see Engine Manual).



3. With the other hand, turn the control lever clockwise to allow the rope to slip on the winch drum and permit a controlled descent. To adjust descent speed, manually control the speed at which the rope leaves the winch. To stop the descent, release the control lever.



USING THE COMPACT VERSION DEVICE - FIXED ANCHORAGE DESCENT PROCEDURE WITH THE COMPACT VERSION

1. Switch off the engine by moving the accelerator control to the " 0 " position.



NOTE!

If the accelerator control does not work, stop the engine by shutting off the carburettor air intake, moving the air lever to the CLOSED position (see Engine Manual).

2. With one hand grasp the rope leaving the winch.

3. With the other hand, turn the control lever clockwise to allow the rope to slip on the winch drum and permit a controlled descent. To adjust descent speed, manually control the speed at which the rope leaves the winch. To stop the descent, release the control lever.

PowerSeat PWRS-G.Compact

USING THE COMPACT VERSION DEVICE - CONVERTING THE POWERSEAT PWRS-G IN THE COMPACT VERSION

To obtain the Compact version from PowerSeat PWRS-G it is required to buy the short tube and follow the procedure described below:



1. Pull open the clamp and slide out the front tube.



2. Unscrew the four screws that fix the seat to the chassis with a n°5 hex Key.



3. Remove the seat.



4. Pull open the clamp and slide the short tube into the housing.



WARNING!

Slide the front tube correctly into its housing until the red reference mark is no longer visible.

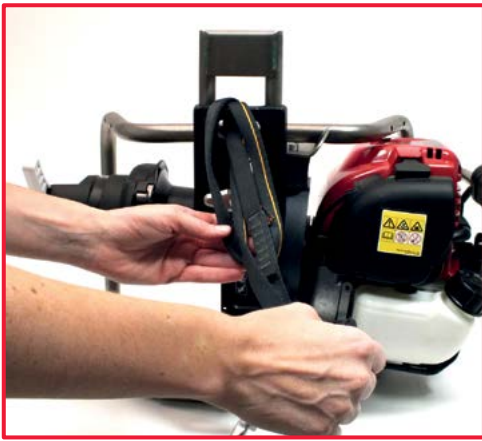

5. Remove the strop from upper anchorage point.



6. Fasten the strop on the lower anchorage point.

Maintenance

CLEANING

Regularly clean and dry the device with a damp cloth to remove accumulated dirt. Do not use a direct jet of water or a high pressure water jet cleaner. Do not use degreasing products, solvents or abrasive pastes.

MAINTENANCE

Before and after every use visually inspect the PowerSeat for traces of wear, damage or breakage. Refer to the “Checking the device before use” paragraph for more detail on this inspection.

Every year, once a year send the device to the manufacturer or to an authorized Harken Service Center for a complete inspection.

The first year, the device must be sent to the manufacturer within 12 months from the date of purchase. The non-observance of such condition invalidates the warranty of the machine.

The maintenance must be recorded in the Maintenance Schedule.

ENGINE MAINTENANCE

For engine maintenance, consult the Engine Manual supplied together with this manual.

Dismantling and Disposal

When the device is dismantled, it is necessary to separate the parts in plastic, those in metal and electrical components, which must be sent to differentiated disposal centres in accordance with the regulations of the country where the device is dismantled.

Diagnosis and Fault Finding

Problem	Possible Causes	Possible Solutions
The rope slips on the winch drum	<ul style="list-style-type: none">- too few turns around the winch drum- diameter of rope not in prescribed range	<ul style="list-style-type: none">- take another turn of the rope round the winch drum- replace the rope
The engine does not start	<ul style="list-style-type: none">- incorrect starting procedure or engine fault	<ul style="list-style-type: none">- consult the Engine Manual
Limited lifting capacity	<ul style="list-style-type: none">- engine malfunction- device used above 1500 m	<ul style="list-style-type: none">- consult the Engine Manual- contact Harken for more information
Difficult descent	<ul style="list-style-type: none">- too many wraps on winch drum- rope grab system possible malfunction	<ul style="list-style-type: none">- unwind the rope, reducing wraps. Leave at least 2 wraps on winch drum- contact Harken for more information

For more information on the correct working of the engine refer to the “Dealing with unexpected problems” paragraph in the Engine Manual.

Maintenance Schedule

Owner name

Product name and Model

Serial Number

Engine Serial Number

Year of manufacture

Date of purchase

Date of first use

Maintenance interval

Annual

HARKEN®

Manufacturer/EU Representative

Harken Italy S.p.A.

Via Marco Biagi 14, 22070 Limido Comasco (CO), Italy

Tel 031.3523511; Fax 031.3520031

Web: www.harken.it

Email: info@harken.it

World Limited Warranty

Refer to the Harken World Limited Warranty on the website at:

<http://www.harkenindustrial.com/technical-information/warranty/>

The product warranty is accepted only if it has been maintained as specified in this Manual by Harken authorized personnel and is accompanied by Maintenance Schedule properly compiled